

# Aviation Security Market Leader

No company can match Analogic's track record of CT innovation and volume production!

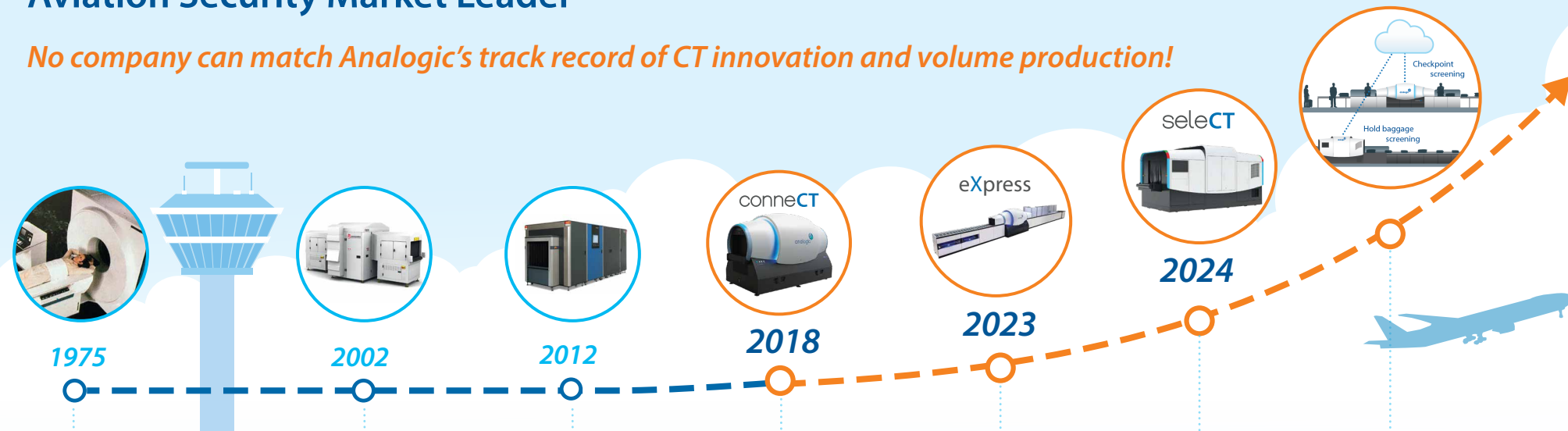

Year	Product	Role	Key Achievements
1975	First instant-imaging CT, 3rd generation data acquisition electronics		
2002	OEM: TSA and international checked baggage screening	OEM supplier	OVER 1,500 SOLD
2012	OEM: First 1800 bph EDS Certified to ECAC STD 3	OEM supplier	600+ SOLD
2018	ConneCT achieves TSA and ECAC Certification	Direct Sales and Service	Awarded CATSA Checkpoint ConneCT & eXpress ATRS
2023	eXpress modular automated tray return system integrated with ConneCT		Awarded >600 TSA Checkpoint lanes
2024	select awarded top-tier European airport		1200 ConneCTs sold with >99.5% fleet Ao

## SeleCT SPECIFICATIONS

<b>DIMENSIONS:</b>	L: 5,143 mm (202.5 in) W: 2,200 mm (86.6 in) H: 2,260 mm (89.00 in)	<b>TUNNEL SIZE:</b>	W: 1020 mm (40.2 in) H: 810 mm (131.9 in)
		<b>WEIGHT:</b>	Approx. <6,000 kg (13,228 lbs)



... transforming the **future of aviation security**



## select™ | HOLD BAGGAGE & AIR CARGO SECURITY SYSTEM

- Next generation 3D image quality for greater levels of detection, lower false alarms, and faster on-screen resolution
- SeleCT-able algorithms enable risk-based screening for enhanced security
- SeleCT-able belt speeds enable intelligent load balancing and reduced energy consumption
- Innovative bearingless design eliminates the need to replace costly bearings, lowers the cost of ownership and dramatically improves reliability
- Futureproof platform with in-situ upgrades to provide enhanced capabilities for a 20+ year lifecycle
- Shares platform-based design with the ConneCT, providing common user interfaces, network, training, service, software, APIs, and parts



Analogic Corporation - Headquarters USA  
8 Centennial Drive, Peabody, MA 01960  
www.analogic.com



**select™** | HOLD BAGGAGE & AIR CARGO SECURITY SYSTEM powered by analogic

The names Analogic and the globe logo are registered trademarks of Analogic Corporation.

**Future-proof innovation, uncompromising security, and next-gen image quality**

## Common operating platform

SeleCT's common operating platform shares core features with other Analogic security solutions such as our ConneCT checkpoint system.

*Result: lower costs, seamless integration, increased revenue velocity.*



- Advanced computed tomography detection
- Open architecture supports third party applications



- Common GUI
- Touchscreen interface
- Cyber hardened



- World Class service, support, and logistics



- Energy-efficient design
- Sustainable components
- Reduced carbon footprint

# CORE DESIGN PRINCIPLES

## Breakthrough gantry design

*Reliable Bearingless Wheel Design* reduces cost of ownership. Replaces traditional bearing design and cuts maintenance costs and system downtime.

**No competitor offers this!**

**Replacement takes under an hour!**

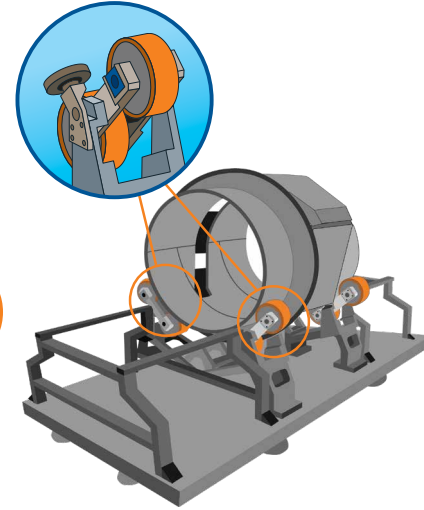

**SeleCT Gantry Design  
GAME CHANGER!**

## Leveraging networking and multiplexing

Supports networking and multiplexing within an airport, across multiple airports – even internationally.

Enables operational efficiency, revenue-creating applications, new business models.

*Supports remote screening solutions to optimize staff productivity and airport real estate.*



### Airport-wide networking

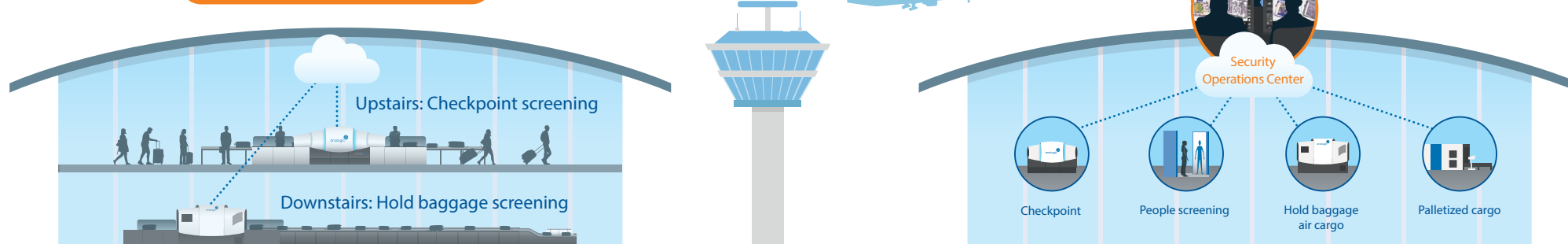

## Checkpoint

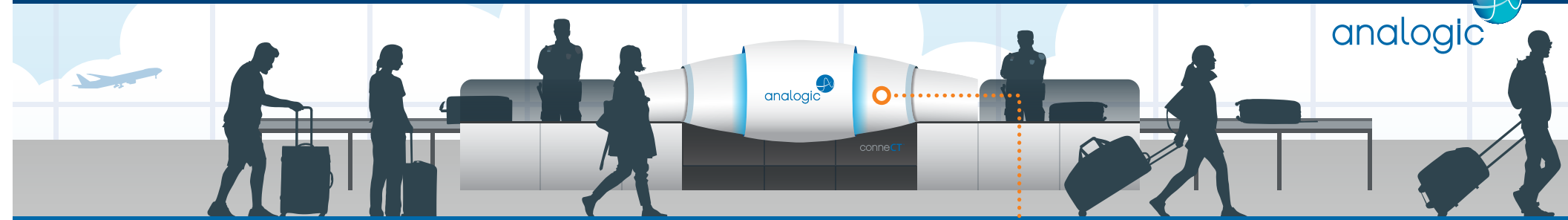

## Checked Baggage



### Common Platform



**Innovative | Image Quality | Future Proof**

